

Minutes:

Historic Falls of the James Scenic River Advisory Committee
5th Floor Conference Room
Richmond City Hall

Meeting: August 17, 2023

Greg Velzy Chair – Presiding

Call to Order: 12:04 PM

Attending Committee Members: Ralph Hambrick, Tricia Pearsall, Jim Hill, Greg Velzy, Lynn Crump, Anne Wright, Alex Dahm, John Heerwald. **Attending Community Representatives:** Giles Garrison-Superintendent of James River Park, City of Richmond, Shade-Office Administrator, Friends of the James River Park, Aimee Bushman, James River Park System's Park Ranger Supervisor,

Minutes: Minutes of June 15, 2023: Move to approve-Alex Dahm, Seconded-Ralph Hambrick, Approved.

Current Issues:

- **Riverfront Development Updates:** Kevin Vonck, Director, Dept. of Planning & Development Review, City Of Richmond: Kevin not present.
- **CRLC Updates:** Parker Agelasto not present but wrote in an email: "At the present time, I don't have much of an update. We're going to push to get the JRPS conservation easement amendment done to add the acreage. It's stalled for too long and we have properties to transfer to the City (i.e., Rogers Woods at Buttermilk Trail West)." Giles Garrison stated that there was a new attorney in the City Attorneys' Office, and she had great hope for the James River Park System's matters.
- **Brown's Island Improvement Plan:** Alex Dahm: Operations Manager, Venture Richmond, Inc.
 - Alex reported that phase #1 of the Plan is the renovation of the area under the Manchester Bridge. Dominion will be expanding its substation which will dovetail with Venture Richmond's Plan to make the stage and area behind more attractive. They will be engaging with architects for plans which will include terraces similar to those recommended in the 2012 Riverfront Development Plan (they will not go all the way down to the River). The terraces will open up the visitor's connection with the river. They're also considering constructing a better defined trail down to the beach area before the pipeline, as well as adding both safety and historic interpretive signage. Once plans are approved, a full fund raising program will begin.
 - Giles added that JRPS had offered (to CSX) to construct a canopy over the Pipeline as part of the negotiations for continued usage of the trail.
 - The City has plans for 30% of improvements to Tredegar Street and the new access to the T-Pott Bridge.
 - Alex also brought up the rewatering of the JR & Kanawha Canal from Venture Richmond's property west (Park Hydro) to Maymont. This would mean that a dike would have to be constructed for access to the switching station for CSX and to Dominion's property. He added that this was Brent Halsey's wish.
 - The canal has been drained as DPU has been doing some repair work.
- **Virginia Scenic Rivers:** Samantha Wangsgard was not present. No report.
- **Scenic Virginia:** Leighton Powell could not be present but Lynn Crump reported:
 - Scenic Virginia has been asked to use its photos from the Scenic Virginia Photo Contests to decorate the new General Assembly building.
 - Lynn is hoping to begin Community Identification visits with communities to start prioritizing important viewsheds. She is continuing to work with VCU to determine a prototype for viewshed analysis for the Viewshed Registry. The first recommendation for the registry has come from the Church Hill Association for Libby Hill. The Registry would be aligned with Conserve Virginia and the website would be housed under

Scenic Virginia's website. Lynn added that the process to evaluate a community's viewshed for inclusion in the registry must be grass roots and evaluation is based on research established by scientists and others.

- **JRA Update:** Justin Doyle
 - Construction of the Buzzard Education Center is ongoing by Kjellstrom & Lee with the framing in place, so one can see the scale of the building. Plans are to open summer 2024.
 - JRA is Working with Cat Anthony and the Virginia Capital Trail to improve trail visibility, access and its location. Very soon the trail will be off Dock Street. There is certainly the option for an alternate trail closer to the river in the future.
 - Justin said he was happy to coordinate 'hard hat' tours. The Committee indicated they would very much appreciate the opportunity.
 - They are also coordinating with DPU for vegetation and stormwater best practices.
 - September 9, 2023 is James River Week coordinated by JRAC. In addition to the river cleanup, JRA will provide sturgeon tours and other programs.
 - October 23rd is the JRA Annual Meeting to be held at Westcreek.
 - Currently JRA is coordinating field trips and programs for the start of the new center's school programs. This will begin for school year 2024-2025. The programs now being run at Deep Bottom Park will move to the new center. The Jordan Point programs will remain in place.
 - Justin acknowledged that dredging must be done to make full use for their dock, both for their boats and for public access. Discussion ensued concerning dredging opportunities for Ancarrows as well as Rocketts Landing Marina. Quotes have been solicited from Harbor Dredge and Dock.
- **James River Park:** Giles Garrison, Superintendent, James River Park.
 - Giles' report is attached as an addendum to the minutes.
 - Giles stated that getting an accurate count of Park visitors has been difficult as counters fail often and reports are too low, but cell phone data is too high.
 - Giles introduced Aimee Bushman, the new Park Ranger supervisor for the JRP System. This is a pilot program working and training with Richmond Police. The program will eventually be used in other Richmond parks.
 - Aimee gave her history in conservation and park administration: <https://jamesriverpark.org/meet-our-newest-parkstar-aimee-bushman/>
 - She told us that interviews for the 2nd Ranger are underway and the candidate should be on boards by the end of September.
 - The mission of ranger is to enforce JRP rules while being an ambassador for JRP. The ranger will carry no arms. Rangers will mainly be a presence on trails and engaging with visitors and violators. To date she has dealt mostly with violators of dog leash regulations but will also be looking for graffiti violations as well as for campfires, etc. There will also be establishing a corps of volunteers, perhaps roaming ambassadors or junior rangers to help with river safety, historic and natural interpretation, etc.
 - Giles and Aimee explain the 311 Program which alerts JRP personnel to trail or other issues. <https://jamesriverpark.org/new-tool-for-reporting-trail-issues/>
 - Giles also reported that she was meeting with DPU to work out the work arounds, etc for the 22nd Street CSO work.
- **DPU:** Grace LeRose not present.
- **Friends of James River Park Report:** Josh Stutz not present but Shawna Shade reported:
 - The Reedy Creek Bypass Trail is ready for use
 - September 21, 2023 is the date of the Camera to Canvas auction featuring 45 artists interpreting the photographic work of Bill Draper. It will be held at the Boathouse. There will be a silent auction as well as live auction, and you can also purchase raffle tickets online. Ralph Hambrick suggested that they also sell John Bryan's book and his as well as Bill Draper's photographic books (and his).
 - Marvel Design is working toward proposing changes and solutions for the structures and design future of Belle Isle. They are looking to improve the hydroplant and the wedge building and will make their presentation to the FoJRP Board. Once adopted, the Friends will then begin a capitol campaign. Right now, there are just ideas. Greg suggested that Marvel provide a walk-through for the Falls Committee members.

- **Falls of the James Bridge Signs:** Tricia has pestered both Theresa Simmons at RMTA and Christopher Hayes at Traffic Engineering, City of Richmond. City signs should go up this Sunday, August 27, 2023.
- **New Falls of the James Scenic River Advisory Committee Members:** Lynn Crump has graciously agreed to come on board and her resumé with accompanying letter has been sent to DCR. Thanks and welcome Lynn! James Vonesh and Nathan Burrell have agreed to join, and we look forward to receiving their resumé's. John Bryan has declined as he's embarking on another book project.

New Business: None

Reports:

JROC – work project at Huguenot flatwater this weekend.

Open discussion: None

Adjourn: 1:35 pm

Next Public Meeting: September 21, 2023

Meetings begin at 12:00 noon in the Conference Room on the 5th floor of Richmond City Hall and/or conducted via Zoom. Meetings are scheduled for the THIRD Thursday of each month. All meetings are open to the public. If you are not now receiving e-mail meeting notices and wish to receive them, please provide your name and e-mail address to velzyg@verizon.net. If you would like to be removed from the list, so indicate at the above e-mail address.

Tricia Pearsall – Secretary

Superintendent Report

Highlights from July 2023

PARK PROJECTS

Reedy Creek Bypass Trail

Construction of the Reedy Creek Bypass Trail is nearing completion (80%), with a new gravel trail laid and fence posts installed. This trail, a JRPS Masterplan objective, will create a safe walking and biking path that provides visitors an improved way to pass JRPS operations headquarters. This project was in large part funded by Friends of James River Park System.

Buttermilk Trail improvements

Trail crew is steadily working on major improvements to a section of the Buttermilk Trail located just east of the Boulevard Bridge. Repurposed stone is being used to develop a serpentine switchback that achieves the dual purpose of saving a large beach tree and preventing erosion. On Buttermilk Trail further east a small rock feature has been added to achieve the same goals: saving a tree by protecting its roots and reducing erosion.

Invasive Tree Removal

The Invasive Plant Task Force is funding the removal of 23 invasive trees located between the Buttermilk Trail and Riverside Drive, beginning in the second week of August. During the week of August 7th- 11th vehicles will be directed away from the project area, which is between 42nd Street and Southcliff Drive on Riverside Drive.

Potterfield Bridge Repairs

The Potterfield Bridge repairs, which include the installation of new fasteners and stiffeners to eliminate side-to-side movement and bowing of bridge grates, are about 30% complete. Walkers will notice a more firm walking surface from Brown's Island to the first observation area. The bridge will continue to remain open, as repairs are being made to the underside of the structure.

UPDATES / ANNOUNCEMENTS

Meteor Shower Bike Ride in August

JRPS outdoor education invites the public to join us for the annual Meteor Shower Bike Ride, an excursion on the Capital Trail to Chickahominy State Park that takes place on August 12-13, 2023. To sign and for more information up email Penelope Davenport at Penelope.davenport@rva.gov.

DPU stormwater project

Department of Public Utilities is currently taking stakeholder input on the impact of stormwater management projects throughout the City of Richmond. One major project is located near the 21st Street pedestrian bridge on the service road from the Belle Isle access bridge to Reedy Creek. This project will begin in spring of 2024 and will entail the replacement of a major stormwater regulator structure. During construction, an alternative route will be created to allow pedestrians to continue moving east-west on the service road. This project is essential to protecting water quality in the James River.



Park visitors can now use RVA 311 to report JRPS issues. The RVA 311 app can be downloaded onto your smart phone or visit <https://www.rva311.com/rvaone/> to make a report online.

Supervisor: Penelope Davenport

Program Specialists: Tyler Twyford, Willa Moffatt

Cidney Oleanx
Joey Binkley



Left: summer educators take our jobs very seriously.
Above: Rose Brown teaches Battery Park campers safe river swimming techniques-- "NOSE and toes stay above the water."

Date	Number Participants	Program Title	Audience	Organization/ Group	Activity
7/3/2023	25	Adventure Hike	Community Center	Humphrey Calder Community Center	Adventure Hike
7/3/2023	20	Forest Hill Fish	Community Center	Blackwell Community Center	Fishing
7/3/2023	20	River Swim	Community Center	Whitcomb Community Center	Swimming
7/3/2023	7	TRIP Waterfront	Teen Workforce Development	Mayor's Youth Academy	Paddling
7/5/2023	25	River Swim	Community Center	Humphrey Calder Community Center	Swimming
7/5/2023	20	Belle Isle Biking	Community Center	Blackwell Community Center	Biking
7/5/2023	20	Forest Hill Fish	Community Center	Whitcomb Community Center	Fishing
7/5/2023	20	Belle Isle Biking	Community Center	Humphrey Calder Community Center	Biking
7/5/2023	7	TRIP Waterfront	Teen Workforce Development	Mayor's Youth Academy	Paddling
7/6/2023	25	River Swim	Community Center	Blackwell Community Center	Swimming
7/6/2023	18	Adventure Hike	Community Center	Whitcomb Court Community Center	Adventure Hike
7/6/2023	7	TRIP Waterfront	Teen Workforce Development	Mayor's Youth Academy	Paddling
7/7/2023	5	Huguenot Flatwater Kayak	Therapeutic Recreation	VA	Paddling

James River Park System Outdoor Education - July 2023

Summer Staff: Caleb Rivera Rose Brown

Nathan Hill Lauren Deluca

Number Participants **827** Number Programs
Evan Watkins Toolen Meyer

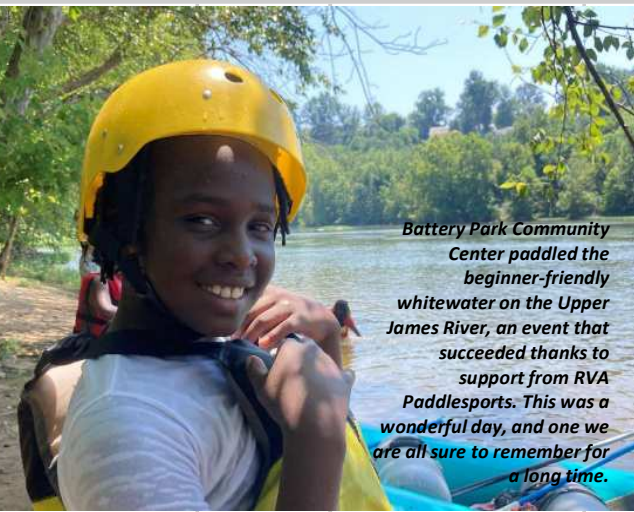

Battery Park Community Center paddled the beginner-friendly whitewater on the Upper James River, an event that succeeded thanks to support from RVA Paddlesports. This was a wonderful day, and one we are all sure to remember for a long time.



Fishing with our friends from the VA.

7/10/2023	7	TRIP Waterfront	Teen Workforce Development	Mayor's Youth Academy	Paddling
7/10/2023	28	River Swim	Private Group	Sacred Heart Center	Swimming
7/10/2023	20	Forest Hill Fish	Community Center	Creighton Court Community Center	Fishing
7/10/2023	20	Belle Isle Biking	Community Center	Ann Hardy Community Center	Biking
7/11/2023	7	TRIP Waterfront	Teen Workforce Development	Mayor's Youth Academy	Paddling
7/11/2023	25	Adventure Hike	Community Center	Creighton Court Community Center	Adventure Hike
7/11/2023	25	River Swim	Community Center	Ann Hardy Community Center	Swimming
7/12/2023	7	TRIP Waterfront	Teen Workforce Development	Mayor's Youth Academy	Paddling
7/12/2023	20	Belle Isle Bike	Community Center	Creighton Court Community Center	Biking
7/12/2023	25	Adventure Hike	Community Center	Ann Hardy Community Center	Adventure Hike
7/13/2023	7	TRIP Waterfront	Teen Workforce Development	Mayor's Youth Academy	Paddling
7/13/2023	13	River Swim	Community Center	Creighton Court Community Center	Swimming
7/13/2023	25	Forest Hill Fish	Community Center Teen Workforce Development	Ann Hardy Community Center	Fishing
7/17/2023	7	TRIP Waterfront	Development	Mayor's Youth Academy	Paddling
7/17/2023	32	Adventure Hike	Community Center	Southside Community Center	Adventure Hike
7/17/2023	20	Belle Isle Bike	Community Center Teen Workforce Development	Randolph Community Center	Biking

7/18/2023	7	TRIP Waterfront	Development	Mayor's Youth Academy	Paddling
7/18/2023	25	River Swim	Community Center	Southside Community Center	Swimming
7/18/2023	25	Adventure Hike	Community Center Teen Workforce	Randolph Community Center	Adventure Hike
7/19/2023	7	TRIP Waterfront	Development Teen Workforce	Mayor's Youth Academy	Paddling
7/20/2023	7	TRIP Waterfront	Development	Mayor's Youth Academy	Paddling
7/20/2023	20	Belle Isle Bike	Community Center	Southside Community Center	Biking
7/20/2023	25	River Swim	Community Center	Randolph Community Center	Swimming
7/21/2023	7	Forest Hill Fish	Therapeutic Recreation	VA-VISOR	Fishing
7/24/2023	14	River Swim	Community Center	Hotchkiss	Swimming
7/24/2023	25	Forest Hill Fish	Community Center	Battery Park Community Center	Fishing
7/25/2023	20	Belle Isle Bike	Community Center	Battery Park Community Center	Biking
7/25/2023	20	Forest Hill Fish	Community Center	Hotchkiss Community Center	Fishing
7/26/2023	27	Adventure Hike	Community Center	Battery Park Community Center	Adventure Hike
7/26/2023	20	Belle Isle Bike	Community Center	Hotchkiss Community Center	Biking
7/26/2023	30	River Swim	Private Group	Sacred Heart Center	Swimming
7/27/2023	12	Upper James Raft Trip	Community Center	Battery Park Community Center	Paddling
7/31/2023	29	Adventure Hike	Community Center	Bellemeade Community Center	Adventure Hike

JRPS Outdoor Education Initiatives

July was a wonderful, crazy, fun, wild, challenging, busy month for the JRPS Education team. We:

Hosted campers from 11 community centers!	Helped teens develop professional skills, including small business management, environmental stewardship, and customer service	Continued community listening and planning to inform drafting an Environmental Literacy Plan for RPS.
Expanded therapeutic recreation programs and built relationships in the TR community	Collaborated with JRPS staff to improve river corridor maps, improving river safety for all Park visitors	Formed a Teacher Advisory Group for the ELP.

We are looking forward to:

Hosting Bellemeade, Powhatan, and Broad Rock Community Centers	Providing field trips for all of Fairfield Elementary School as part of the 200 day pilot year.	Meeting with our Teacher Advisory Group to begin drafting the ELP	Reflecting on a busy summer and planning for an even better 2024
--	---	---	--

James River Park System Volunteers - July 2023

Hours of Service **543**
Events Completed **32**
Total Volunteers **224**
 Average Hours per volunteer 2.4
 Avg. Volunteers per event 7.0



US Army on the Buttermilk Trail



BDO Pony Pasture Cleanup

Metric Summary

	Cleanups	Invasives
Hours of Service	198	345
Average Hours per volunteer	2.00	2.76
Events Completed	10	22
Avg. Volunteers per event	9.90	5.68
Total Volunteers	99	125

Date	Number Volunteers	Duration	Hours Served	Project	Invasive (Y/N)
7/1/2023	15	2	30	James River Cleanup	No
7/5/2023	4	2	8	James River Cleanup	No
7/8/2023	12	2	24	James River Cleanup	No
7/12/2023	15	2	30	James River Cleanup	No
7/15/2023	1	2	2	James River Cleanup	No
7/19/2023	6	2	12	James River Cleanup	No
7/20/2023	21	2	42	BDO - Pony Pasture Cleanup	No
7/22/2023	4	2	8	James River Cleanup	No
7/26/2023	12	2	24	James River Cleanup	No
7/29/2023	9	2	18	James River Cleanup	No
7/7/23	6	3	18	Ancarrow's Invasive Management	Yes
7/14/23	6	3	18	Ancarrow's Invasive Management	Yes
7/21/23	2	3	6	Ancarrow's Invasive Management	Yes
7/28/23	1	3	3	Ancarrow's Invasive Management	Yes
7/6/2023	8	3	24	Belle Isle Invasive Management	Yes
7/13/2023	10	3	30	Belle Isle Invasive Management	Yes
7/20/2023	4	3	12	Belle Isle Invasive Management	Yes
7/27/2023	11	3	33	Belle Isle Invasive Management	Yes
7/1/2023	1	2	2	Buttermilk Invasive Management	Yes
7/8/23	8	2	16	Buttermilk Invasive Management	Yes
7/15/23	1	2	2	Buttermilk Invasive Management	Yes
7/22/23	5	2	10	Buttermilk Invasive Management	Yes
7/29/23	5	2	10	Buttermilk Invasive Management	Yes
7/6/23	4	2	8	Free a Tree	Yes
7/20/23	1	2	2	Free a Tree	Yes
7/27/23	1	2	2	Free a Tree	Yes
7/25/23	4	2	8	Pony Pasture Invasive Management	Yes
7/1/23	15	3	45	Wetlands Invasive Management	Yes
7/8/23	9	3	27	Wetlands Invasive Management	Yes
7/15/23	9	3	27	Wetlands Invasive Management	Yes
7/22/23	7	3	21	Wetlands Invasive Management	Yes
7/29/23	7	3	21	Wetlands Invasive Management	Yes

JRPS Invasive Plant Management

July 2023

VOLUNTEER EVENTS

- Total number of events: 20
- Total number of volunteer hours: 247
- Total number of volunteers at events (non-discrete, includes repeats): 103
- Park units covered by events: Huguenot Flatwater, Pony Pasture, The Wetlands, Reedy Creek, Buttermilk Trail, Belle Isle, and Chapel Island plus Forest Hill Park.
- Events by project leaders: JRPS (10); IPTF volunteers (9); JRA (1)
- Primary activities: removal and treatment of invasive shrubs and Free-A-Tree
- Reduction in volunteer events due to species-specific treatment demands and seasonal conditions and hazards.

SPECIES OF FOCUS

- [Japanese stiltgrass](#) (*Microstegium vimineum*), an annual grass that has heavily invaded park trailsides and woodland openings, is the treatment focus for July. It is mature but has not reached full density and height making it more management to treat with foliar treatment.
- Method of treatment: foliar spray using backpack sprayers; 1% rate of RoundUp Custom diluted in water w/marker dye and no surfactant. This low rate has proven to be effective per monitoring five days to a week following treatment. This concentration is squarely within recommendations of VDOF, various university extension cooperatives, and other reputable sources. Staff post signs along trails at time of treatment. Mix is rain-fast within two to three hours.
- Co-occurring invasive species treated at the same time include Beefsteak Plant, Lady's Thumb/Asian jumpseed, Japanese Hops, and Cinnamon Vine (Air Potato).

PROFESSIONAL DEVELOPMENT

- Em Robertson and Megan Lowe are enrolled in the Chesapeake Bay Foundation's VoiCeS program (Volunteers as Chesapeake Stewards).
- Laura Greenleaf is working on the Terrestrial Invasive Plant Management Certificate Course (North America Invasive Species Management Association).
- Gera Williams recently became licensed as a Certified Commercial Applicator with VDACS, allowing her to provide the required direct supervision hours for those training to become Registered Technicians.

Operations Report

JRPS Park Operations: July, 2023

Park Visitation in June 2023:

176,609

1,130,082 Year-to-Date

Projects

- 7/2 – 22nd st. bush hogging
- 7/6 – JRA Site Preparations
- 7/12 – Shipping Container Delivery to Belle Isle ☐ 7/15 – JROC Workday Williams island portage trail!
- 7/18 – North Bank Tower Closure and Game Camera install
- 7/22 – Powhite Park Entrance clearing
- 7/22 – Boat Ramp clearing at HFW
- 7/24 – Installed New River Level Flip Sign
- 7/26 – Created 22nd entrance sign

7/2 – 22nd st. hill side renovation

A strategic approach is being implemented this year to remedy the invasive mulberry problem in this parking lot

- Bush hog targeted invasive zones
- Apply foliar applications of herbicide
- Tarp and mulch wooded area

These steps are done at very specific times in the year to yield the best results and hopefully eradicate the mulberries through their root systems. After a successful removal, JRPS will develop a landscaping plan to prevent erosion and replace with natives in the future



7/6 – JRA Site Conference Prep

A new park has just been added just east of The Great Shiplock Park. This 5 acre parcel will host the new building for the James River Association and will feature walking trails and landscaping for park users to enjoy. To celebrate this recent land acquisition, the Parks Department hosted a viewing to demonstrate the potential of this future park



7/12 – Belle Isle Shipping Containers

Two 16' shipping containers have been purchased for use on Belle Isle. One of which will be shared between the Richmond Tree Stewards and Passages' Summer Camp for miscellaneous tool storage. The other shipping container will be used for Trails and Greenway's division to help maintain the trails and bike features.



7/15 – JROC Workday: Williams Island Portage

Hearty JROC volunteers paddled across the James to begin establishing a portage trail connector on Williams Island. The goal of this trail is to connect the two “Exit River Here” signs recently installed, and allow users to make portage easier to avoid the Z Dam.



7/18 – North Bank Tower Closure

Park staff continue to ensure the entrance to the North Bank Tower remains closed to the public due concerns over the safety of the bridge and tower. A monitoring device was installed to respond to break-ins more quickly.



7/22 – Powhite Park Entrance Clearing

Cleared the entrance to Powhite Park.

- Invasive tree removal
- Crown raising / limb pruning
- Hillside bush hogging
- Vegetation clearing
- mulching



7/22 – HFW Boat Ramp Clearing

High water events cause this ramp to fill with silt deposits. JRPS will have to routinely remove the silt to when floods above 10 feet occur.





7/24 – New River Level Sign Install

A new River Level Flip Sign has been installed. This design will replace existing signs throughout the park locations in the near future.

7/26 – 22nd Park Entrance Sign

Developed a new park entrance sign. This sign will be installed on the parcel of land as you exit the Lee Bridge on the south side of the river.

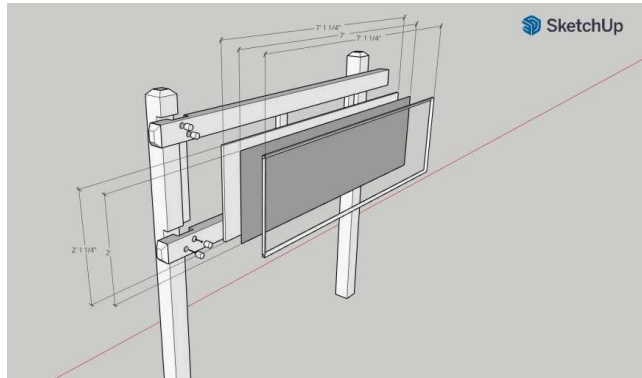

Trails & Greenways Report

July 2023

BUTTERMILK RE-ROUTE

During July the re-route of the Buttermilk Trail started to take shape. The Trails Team has developed a solution to erosion and damage to a mature Beach tree that entails the creation of a sustainable re-route. This strategy prevents future erosion, saves the tree from loss, and makes use of Richmond granite as retaining walls. This project continues in August with further trail benching, re-vegetation of eroded locations, and completion of the switch back.



Further east on the Buttermilk Trail, the crew created a similar erosion reducing and treeprotecting feature. These projects have the impact of enhancing the trail for recreational users while more effectively protecting the James River and its natural resources.



CITY-WIDE PROJECTS

Trail crew responded to a variety of requests throughout the city in July.

- Closed a section of the Gillies Creek “Brownway” trail to support a Department of Public Utilities combined sewer overflow (CSO) project
- Repaired a washed-out section of Petronius Jones walking track
- Removed rotted fence materials from Belle Isle

311 REPORT OUT

Trail service requests can now be made by calling 311 or going to rva311.com. The table below shows closed service requests from July 1 – August 4, 2023.

Year Service Type	2023		Total	
	July	August	Total	
Report Issue on Richmond Park Trail	7	1	8	8
Overgrown vegetation on trail	1		1	1
Safety issue or hazard on trail	2	1	3	3
Tree down or damaged on trail	4		4	4
Total	7	1	8	8